

Isometric View

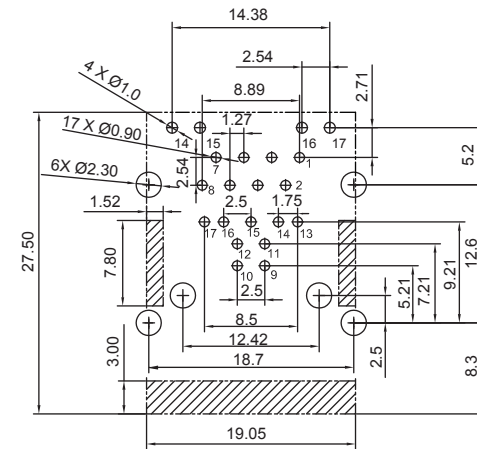
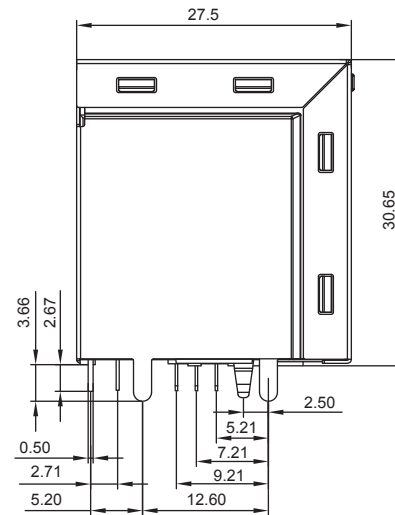

Recommended PCB Layout

HOW TO ORDER:

U A 0 0 - 0 1 7 0 - G Y X - Z

USB CONNECTOR:
7 - 1 USB 3.0 TYPE B CONNECTOR (BLUE)

RJ-45 CONNECTOR:
0 - STANDARD (8P8C)

LED 1: GREEN
LED 2: YELLOW

RoHS COMPLIANT

SELECTIVE PLATING:
6 - Au FLASH CONTACT AREA
7 - 10u" Au CONTACT AREA
8 - 15u" Au CONTACT AREA
9 - 30u" Au CONTACT AREA

TAB OPTION:
1 - w/OUT EMI SPRING TABS

MECHANICAL:
DURABILITY: 750 Mating Cycles Min.
OPERATING TEMPERATURE: -45°C to +80°C

ELECTRICAL:
CURRENT RATING: 1.5A Max.
CONTACT RESISTANCE: 30 milliohm Max.
INSULATION RESISTANCE: 500 Megaohm Min.
DIELECTRIC WITHSTANDING VOLTAGE:
1000 VAC RMS 50 Hz. or 60 Hz. 1 Min.

MATERIAL:
INSULATOR: PBT (UL94V-0)
COLOR: Black
CONTACT: .45mm Phosphor-Bronze
PLATING: Specified Gold Thickness in Contact Area;
Au Flash on Solder Tail; All over 50u" Nickel Subplate
SHELL: Nickel Plated Copper Alloy

Rev	Drawn	Checked	Approved	Date
0	B.S.	S.M.	S.M.	08/15/18

SMP TECHNOLOGY, INC.	
Combo Jack; RJ45 w/ LED + USB 3.0 Type B, No EMI Tabs	